

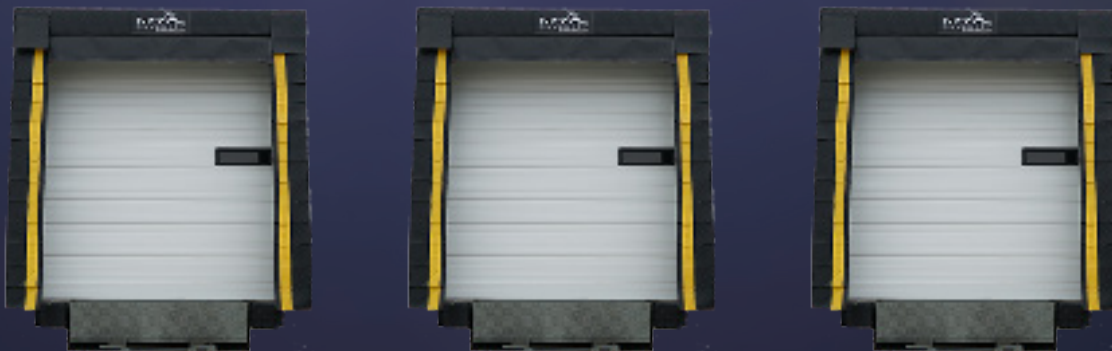

... YOUR PARTNER IN
LOADING DOCK SAFETY AND EFFICIENCY SOLUTIONS



NOVA DOCK SEALS & SHELTERS

NOVA SEALING SYSTEMS



At NOVA, our expert production team combines pride in workmanship with superior design and select-grade raw materials to manufacture products of optimal quality. We offer a wide variety of seals and shelters to fit your facility's needs for vehicle type, door size, dock height, driveway grade, dock traffic and weather conditions. NOVA works with our nationwide network of dealers to ensure that you receive the model most suited to your needs — custom fit to your loading dock.

MAXIMUM ENERGY SAVINGS:

- Weather-tight enclosures keep moisture out
- Seals gaps to prevent warm/cold air infiltration
- ROI from energy savings pays for the sealing system in 2 years

EXCEPTIONAL VERSATILITY:

- Several styles available to accommodate any type of truck
- Designed to fit doors up to 12-feet wide and 12-foot high
- Options for larger doors also available
- Tapered for grade of approach

EXTREMELY COST EFFECTIVE:

- Lowers energy use and overhead expenses
- Improves employee safety, and productivity
- Provides added freight protection
- Increases building and trailer security
- Docked trailers can be used for storage

ROBUST PERFORMANCE & DURABILITY:

- Rugged construction for high-traffic docks
- Top-grade cover material and optional wear pleats for enhanced durability
- Variety of fabric types and weights to choose from
- High-density polyurethane foam for added resiliency
- Frames are made of pressure-treated, kiln-dried wood
- Heavy-duty galvanized mounting hardware
- Shelters include steel support bumpers
- Seals have brass grommets with spur washers for venting
- Velcro® brand attachments
- All sew lines are lock-stitched and reinforced with UV-resistant thread

 **WARNING:** This product can expose you to chemicals including lead, which are known to the State of California to cause cancer or birth defects or other reproductive harm. For more information go to www.P65Warnings.ca.gov

NOVA SEALING SYSTEMS

SEALING SYSTEMS

Sealing systems seal off the space between a parked trailer and the building (Figure 1). They help maintain the internal climate and protect the freight against damage.

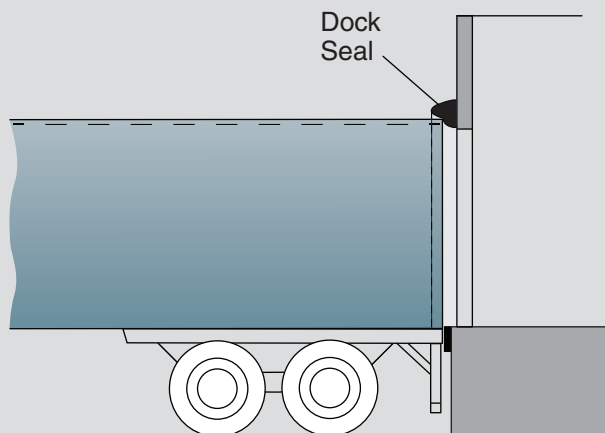

Figure 1

SEALING SYSTEMS HAVE MANY BENEFITS:

- **Energy savings**—reduces overhead costs by maintaining the building's interior temperature and preventing heating/air conditioning from escaping.
- **Safety and productivity**—eliminates dangerous precipitation from the loading areas. Worker productivity correlates to the workplace environment and its safety.
- **Freight protection**—protects freight against harmful weather and minimizes entry of vermin.
- **Security**—prevents product theft and unauthorized entry.
- **Storage**—docked trailers become secure, climate-controlled extensions of the building.

THERE ARE TWO TYPES OF SEALING SYSTEMS:

- **Compression foam dock seals**—the seals are made of high-density polyurethane foam padding with heavy-duty cover material and wear pleats. They are mounted to the wall at the loading door and compress against the back of the truck.
- **Truck shelters**—truck shelters have a rigid frame, a head curtain and side curtains with fiberglass stays. The frame is installed to the building wall and the curtains seal against the wall and the side of the truck (Figure 2).

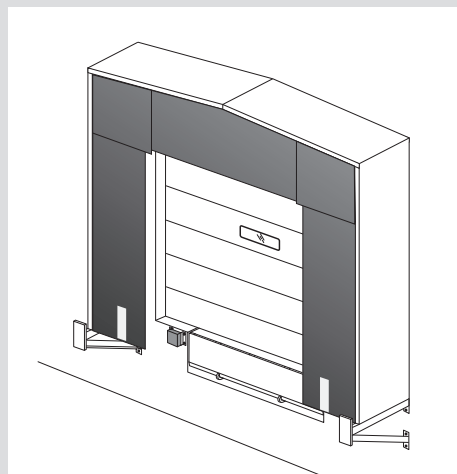

Figure 2

Both seals and shelters use abrasion-resistant industrial fabrics on their sealing surfaces to resist wear from the trailer movement during loading and unloading.

The building wall construction may determine the most suitable type of sealing system. Dock shelters are recommended when walls are not designed to handle the high compression forces of traditional seals.

1-800-236-7325
www.novalocks.com

NOVA SEALING SYSTEMS

SELECTION CRITERIA

Proper selection is the most important aspect of sealing system installation. Improper selection can result in not only a poor installation, but also product damage and decreased productivity. When selecting a sealing system, choose a system that is the most effective at sealing the majority of vehicles being serviced.

Grade of Approach

The grade of approach might be level, declined or inclined.

If necessary, seals can be tapered to ensure parallel compression along the entire face of the side pads, which creates an effective seal.

Overhead Door Dimensions

The size of the door opening determines the most suitable sealing systems.

Dock Bumper Projection

The dock bumper projection is the distance between the wall and the front face of the bumper. On declined driveways, the bumper must project far enough to prevent trucks from impacting the upper wall.

Dock Height

The dock height is the distance between the grade and the top of the dock floor.

Mounting Surface

The wall construction may determine the most suitable type of sealing system. Dock shelters are recommended when walls are not designed to handle the high compression forces of traditional seals.

COMPRESSION FOAM DOCK SEALS

Compression foam dock seals are more effective for sealing than using a shelter system.

- Can be used on doors up to 9-feet wide
- To optimize contact with the truck, seals can be tapered to match the drive approach
- Not recommended for use with trucks with rear loading platforms (Figure 3)
- Must be sized appropriately for the best access to the interior of the truck
- Seals the building to conserve energy
- Economical—provides a return on investment in energy savings
- Some states offer energy rebates

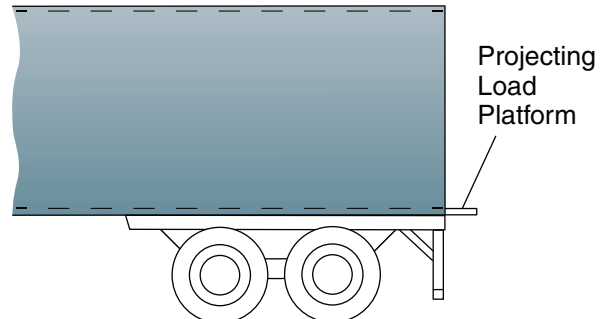

Figure 3

Install the seals with an opening between 7'4-inch and 7'8-inch (Figure 4). Use bevel seals for a loading door wider than 7'8-inch (Figure 5).

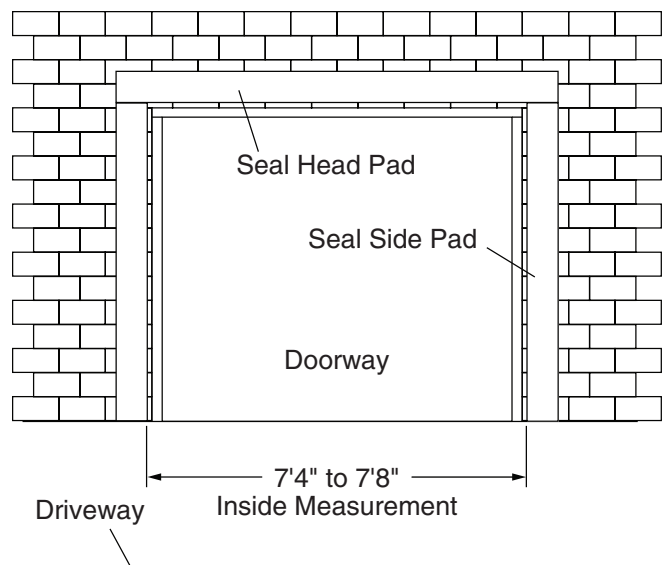

Figure 4

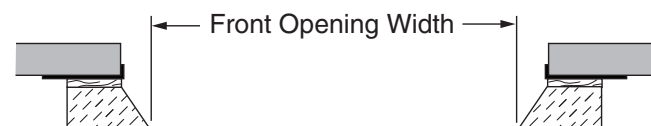

Figure 5

Maintain a minimum of 3-inches between the bottom edge of the head pad and the top of the truck (Figure 6). Various head pad heights are available. Use a fixed head curtain instead of head pads for tall doorways and a wider range of trailer heights (Figure 7).

NOVA SEALING SYSTEMS

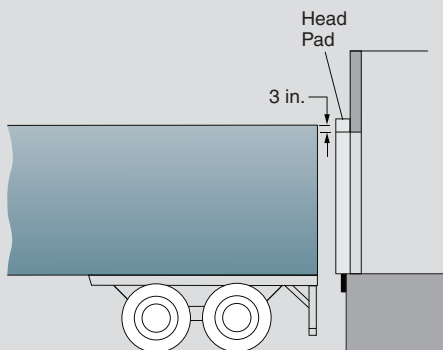

Figure 6

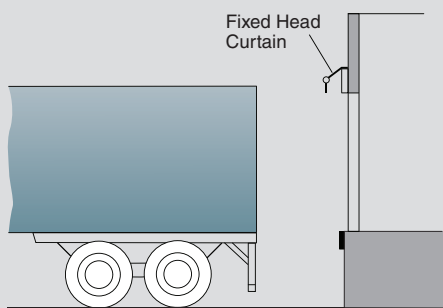

Figure 7

Guidelines for compression foam dock seal installation:

- Per square foot of pad length—approximately 80-pounds of compression force on building
- Distance from wall to the face of the dock bumper—minimum of 4-inches
- Pad projection beyond the bumper—minimum of 4-inches, maximum of 8-inches; 6-inches is nominal
- For recessed driveways with a slope of more than 2%—specify a taper seal; for every 1% of driveway grade, taper the seal 1-inch for overall length (Figure 8)

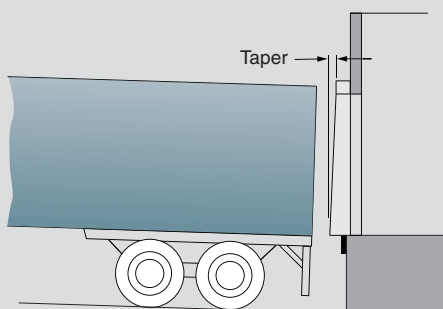

Figure 8

TRUCK SHELTERS:

A truck shelter allows for full access to the interior of the truck. An air gap may still be present around the hinge area of the truck's door.

Dock shelters can be installed on nearly any door but are usually installed on doors between 9-feet wide x 9-feet high and 12-feet wide x 12-feet high.

Use truck shelters for:

- Loading doors wider than 9-feet or higher than 10-feet
- Trucks with extended tailgates
- Trucks with rear platforms (Figure 3)
- Full access of truck's interior

Guidelines for truck shelter installation:

- Minimum shelter width – 11-feet wide (O.D.) measured across the side frames
- Standard opening width – 7-feet wide (I.D.) measured between the insides of the side curtains

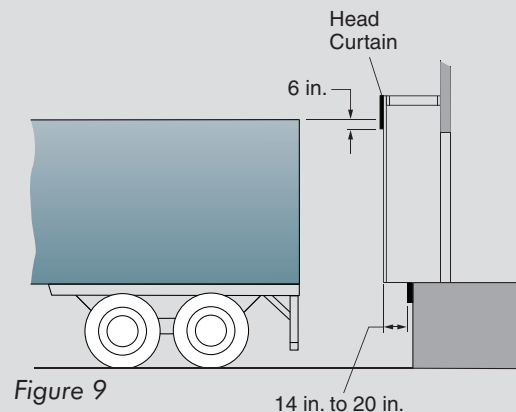
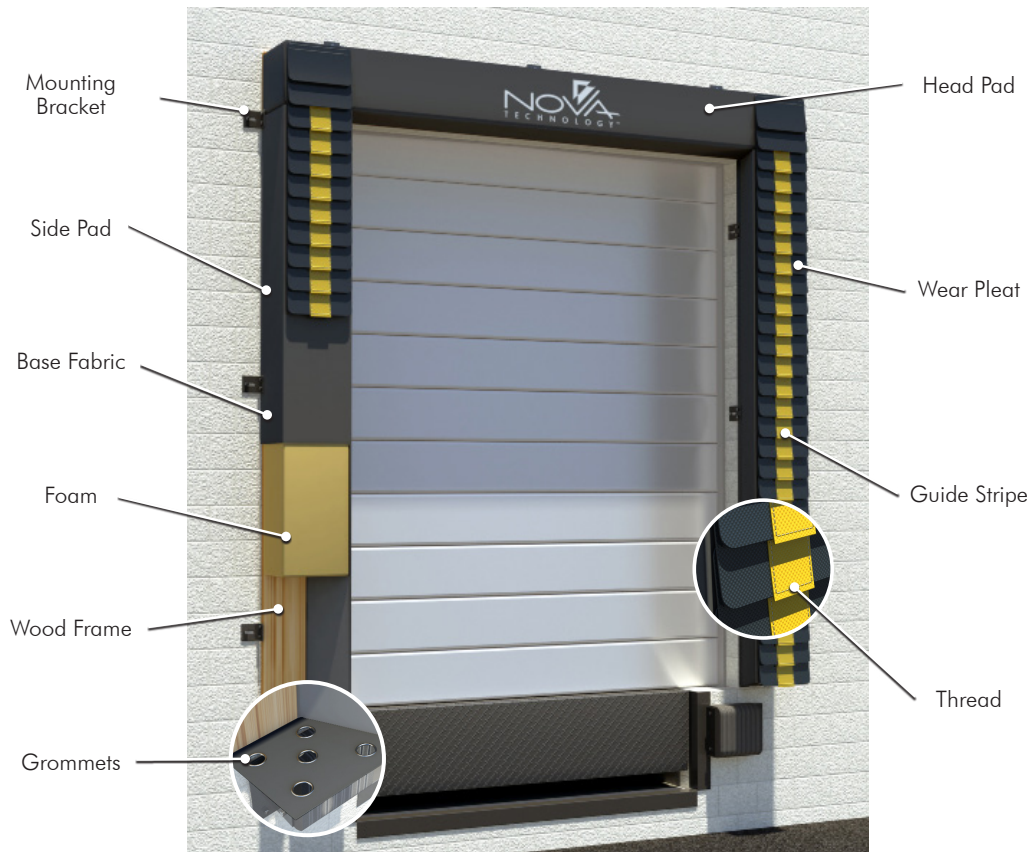

Figure 9

- Position on bottom edge of head curtain – 6-inches below height of the lowest expected truck (Figure 9)
- Top of shelter—minimum of 18-inches above top of highest expected truck. Commonly 15-feet off top of grade
- Shelter projection in front of dock bumpers – 14 to 20-inches
- Install the support brackets for a rigid shelter on the building foundation, flush with the dock floor; the support brackets should project past the shelter frame by 3 to 6-inches

NOVA FOAM PAD (FP) DOCK SEAL



DESIGNED FOR DOOR OPENINGS UP TO 9-FEET WIDE X 9-FEET HIGH

FP Series Dock Seal—the foam-filled head pad and side pads provide a tight, energy-efficient seal between the trailer and dock wall providing protection from inclement weather, dirt and insect infiltration.

- Available in several top-grade fabric types, weights and colors
- High-density polyurethane foam for added resiliency
- Frame is made from pressure-treated, kiln-dried wood
- Foam is bonded to the frame with high-strength adhesive
- Heavy-duty galvanized mounting hardware
- Ventilation slits ensure proper air circulation
- Velcro® attachments
- All sew lines are lock-stitched and reinforced with UV-resistant thread
- Full-height yellow guide stripe

OPTIONS:

- Wear pleats
- Wear face
- Scuff guards
- Bottom door flaps (one to three sides)
- Drop curtains
- Pull rope for drop curtains
- 2-inch foam-filled drop curtains
- Flame-retardant fabric
- Top corner pleats only
- 24-inch yellow guide stripe
- Blockouts
- Galvanized metal backs
- Chain-weighted drop curtain
- Beveled head pads

NOVA FOAM PAD HOOD (FPH) DOCK SEAL

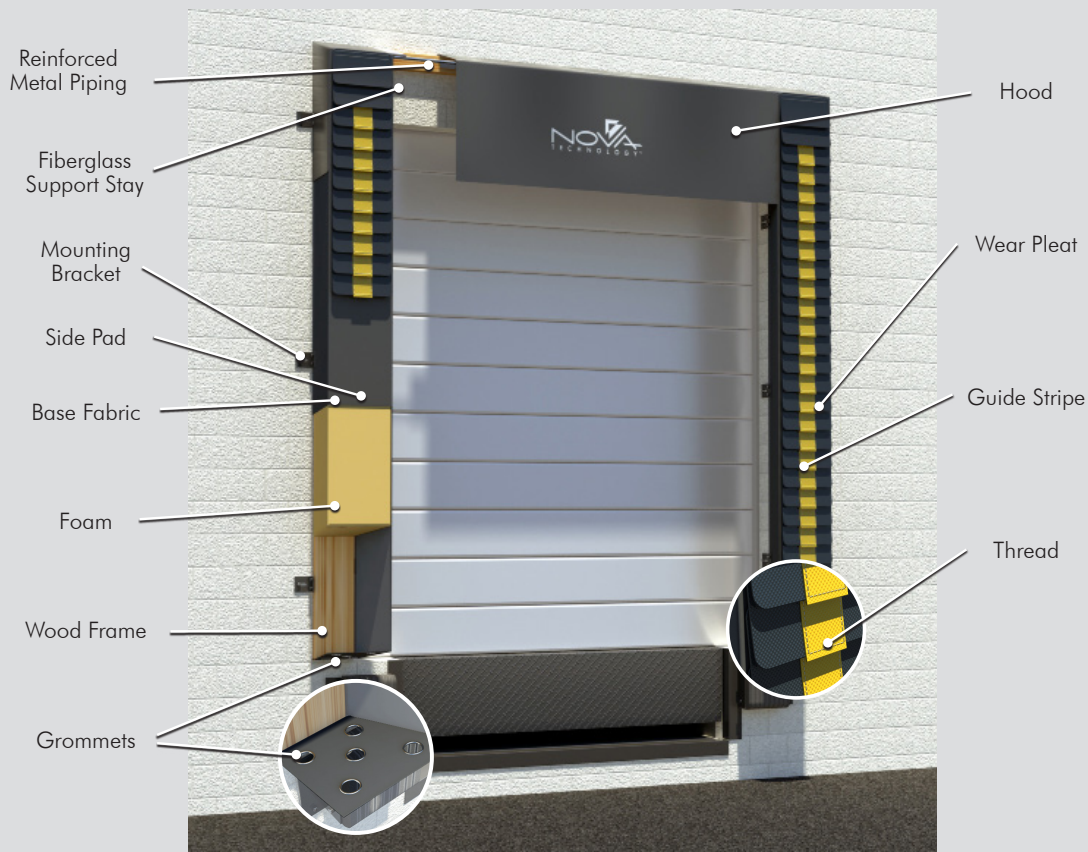

DESIGNED FOR DOOR OPENINGS UP TO 9-FEET WIDE X 12-FEET HIGH

FPH Series Dock Seal—features a hood-style head curtain in place of a head pad with a metal pipe and fiberglass stays in the fabric hood to maintain support and serviceability.

- Available in several top-grade fabric types, weights and colors
- High-density polyurethane foam for added resiliency
- Frame is made from pressure-treated, kiln-dried wood
- Foam is bonded to the frame with high-strength adhesive
- Hood drop can be customized to accommodate various truck heights
- Metal pipe and fiberglass stays for added support
- Heavy-duty galvanized mounting hardware
- Ventilation slits ensure proper air circulation
- Velcro® attachments
- All sew lines are lock-stitched and reinforced with UV-resistant thread
- Full-height yellow guide stripe

OPTIONS:

- Wear pleats
- Wear face
- Scuff guards
- Bottom door flaps
- Pull rope for hood
- Flame-retardant fabric
- Top corner pleats only
- 24-inch yellow guide stripe
- Blockouts
- Galvanized metal backs
- 2-inch foam-filled front on hoods
- Chain-weighted drop curtain

NOVA FOAM PAD UNIVERSAL (FPU) DOCK SEAL



DESIGNED FOR DOOR OPENINGS UP TO 10-FEET WIDE X 9-FEET HIGH

FPU Series Dock Seal—accommodates larger doors and features foam-filled head and side pads that provide a positive seal. The tight, energy-efficient seal between the trailer and dock wall protects the dock from inclement weather, dirt and insect infiltration.

- Available in several top-grade fabric types, weights and colors
- High-density polyurethane foam for added resiliency
- Frame is made from pressure-treated, kiln-dried wood
- Foam is bonded to the frame with high-strength adhesive
- Heavy-duty galvanized mounting hardware
- All sew lines are lock-stitched and reinforced with UV-resistant thread
- Full-height yellow guide stripe
- Ventilation slits ensure proper air circulation

OPTIONS:

- Wear pleats
- Wear face
- Scuff guards
- Bottom door flaps (one to three sides)
- Chain-weighted drop curtain
- 2-inch foam-filled drop curtain
- Flame-retardant fabric
- Top corner pleats only
- 24-inch yellow guide stripe
- Blockouts
- Galvanized metal backs

NOVA FOAM PAD HOOD UNIVERSAL (FPHU) DOCK SEAL



DESIGNED FOR DOOR OPENINGS UP TO 10-FEET WIDE X 12-FEET HIGH

FPHU Series Dock Seal—features a fabric hood-style curtain and foam side pads. This model accommodates taller doors and provides a positive seal against the truck sides.

- Available in several top-grade fabric types, weights and colors
- High-density polyurethane foam for added resiliency
- Frame is made from pressure-treated, kiln-dried wood
- Foam is bonded to the frame with high-strength adhesive
- Heavy-duty galvanized mounting hardware
- All sew lines are lock-stitched and reinforced with UV-resistant thread
- Full-height yellow guide stripe
- Ventilation slits ensure proper air circulation

OPTIONS:

- Wear pleats
- Wear face
- Scuff guards
- Bottom door flaps
- Pull rope for hood
- Chain-weighted drop curtain
- Flame-retardant fabric
- Top corner pleats only
- 24-inch yellow guide stripe
- Blockouts
- Galvanized metal backs
- 2-inch foam-filled front on hoods
- Sectional foam front
- Hood drop can be customized to accommodate various truck heights

NOVA DAIRY SEAL

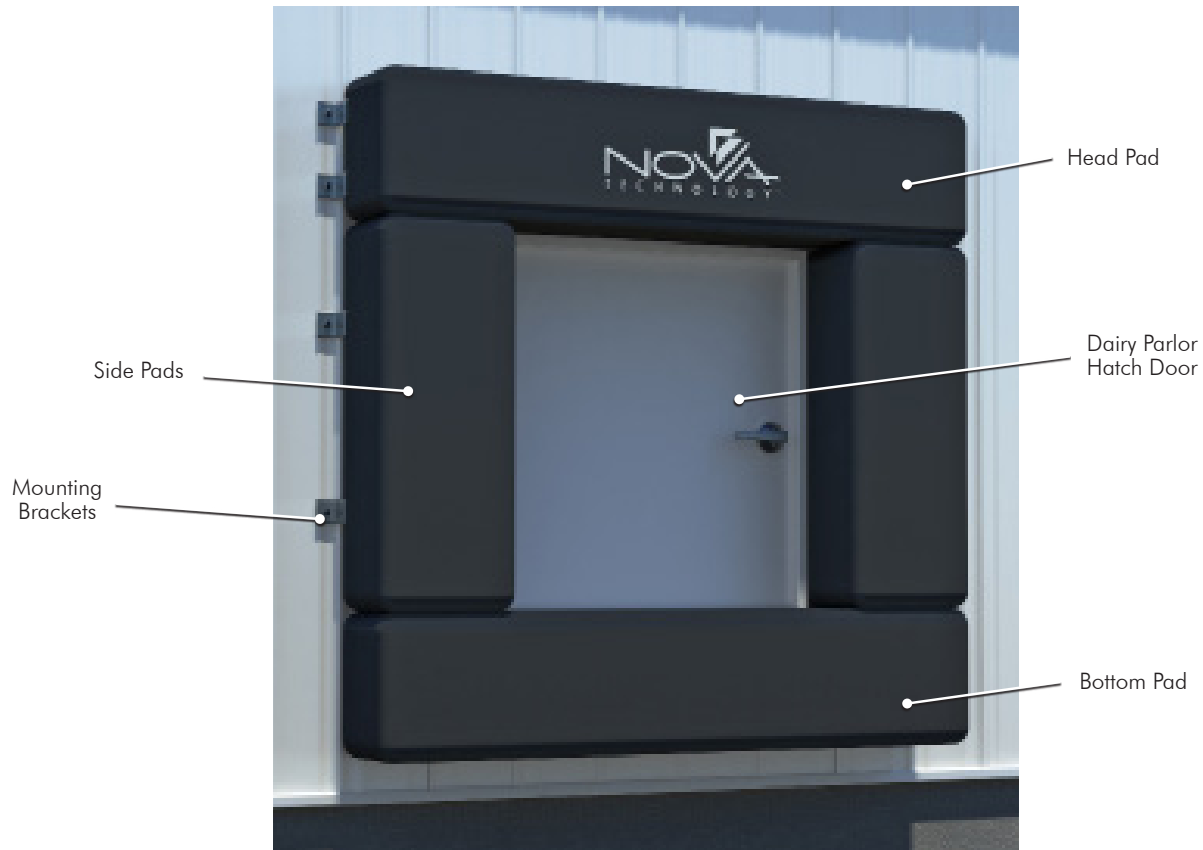

DESIGNED TO FIT ANY SIZE HATCH DOOR

Dairy Seal—designed specifically to enclose a hatch door, this four-sided seal is made for milk tanker trucks to back up against. Milk from dairy cows that has been instantly cooled in holding tanks inside the facility is transferred directly to the tanker. A good seal is necessary to prevent insects, pests and debris from contaminating the transfer process and to meet FDA inspections.

- Typical hatch opening measures 34 x 34-inches
- Standard pads have a 12-inch face and back
- 10 or 12-inch projection
- Available in several top-grade fabric types, weights and colors
- High-density polyurethane foam for added resiliency
- Frame is made from pressure-treated, kiln-dried wood
- Foam is bonded to the frame with high-strength adhesive
- All sew lines are lock-stitched and reinforced with UV-resistant thread

OPTIONS:

- Custom sizes available
- Stainless steel brackets and hardware

NOVA RIGID FRAME (RF) DOCK SHELTER

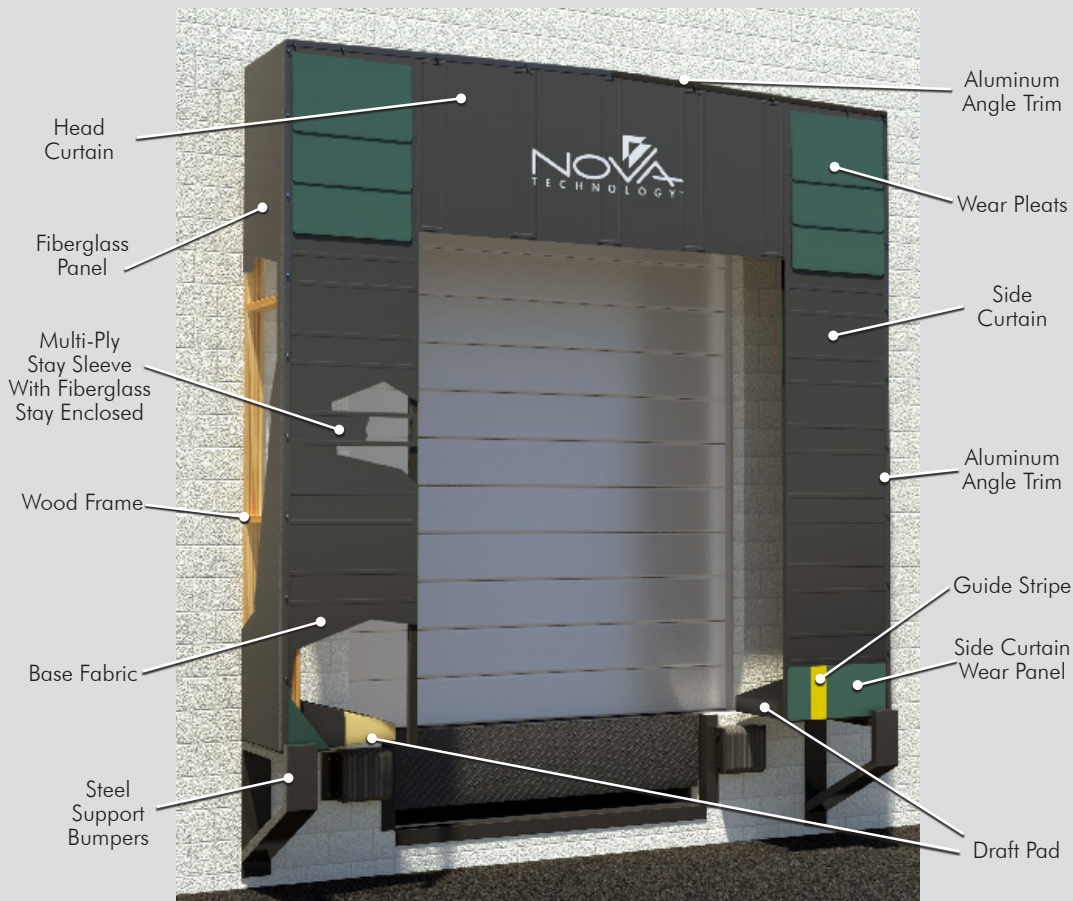

DESIGNED FOR DOOR OPENINGS UP TO 12-FOOT WIDE X 12-FOOT HIGH AND HIGHER DOORS

RF Series Dock Shelter—provides maximum dock protection and full access to trailers while minimizing pressure on the building wall. The RF Series features high wear-resistant fabric with double lock-stitched seams, bottom corner draft pads, protective corner reinforcement pleats, wind retention straps and a 36-inch drop head curtain with fiberglass stays. The raked header with translucent fiberglass top provides natural light, permits water drainage, and provides snow load support.

- Side and head frames are made of pressure-treated, kiln-dried wood
- Frames are covered with translucent fiberglass
- Aluminum angle face edging
- Available in several top-grade fabric types, weights and colors
- Vinyl-covered foam drop-in style draft pads
- 24-inch shelter projection
- Steel supported bumpers (black)
- Heavy-duty galvanized mounting hardware
- All sew lines are lock-stitched and reinforced with UV-resistant thread
- 15-inch yellow guide stripe

OPTIONS:

- Full-height yellow guide stripes
- Custom height, projection and head curtain
- 2-inch foam-filled front head curtain
- Pull rope for head curtain
- Hook and loop splits on head curtain
- Frame cut-outs for obstructions
- Non-projecting frame
- Common member units
- Ground-level units
- 18-ounce white vinyl on frames
- Galvanized steel frame
- Chain-weighted drop curtain
- Spring steel stays

NOVA GAP SEALER (GS) DOCK SHELTER

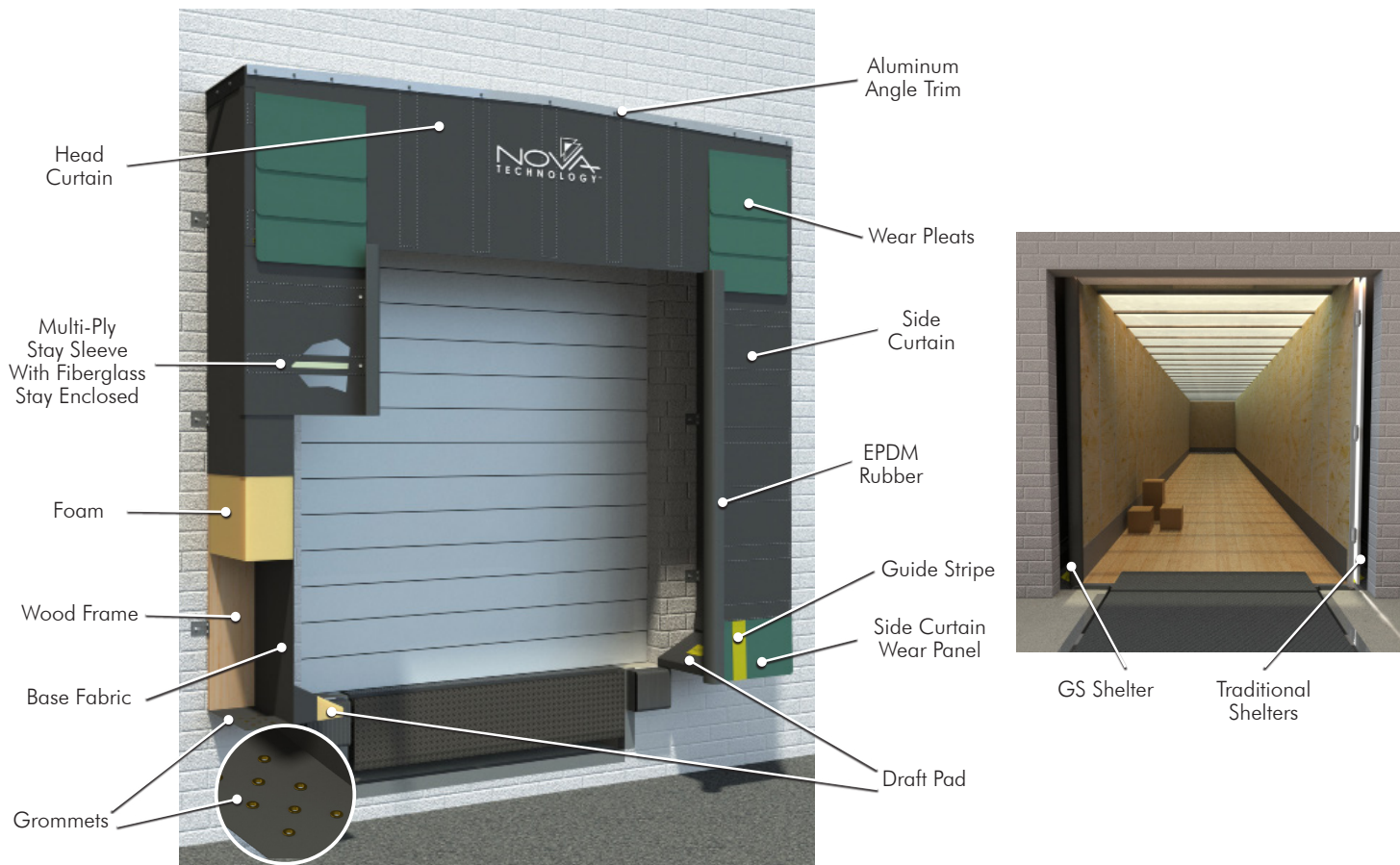

DESIGNED FOR DOOR OPENINGS UP TO 12-FEET WIDE X 12-FEET HIGH

GS Series Dock Shelter—engineered for use with swing-door trailers, the GS Dock Shelter seals the air and light gaps at door hinges while still allowing full access into the trailer. This shelter provides maximum dock protection while minimizing pressure on the building wall. Utilizing foam side pads in its construction, the shelter is capable of compressing and bending out of the way of a truck that approaches the dock off-center preventing costly repairs.

- Durable rubber trim blocks air and light gaps
- Flexible side pad structure protects the unit against damage from off-center trailers
- High-density polyurethane foam for added resiliency
- Frame is made from pressure-treated, kiln-dried wood
- Foam is bonded to the frame with high-strength adhesive
- Available in several top-grade fabric types, weights and colors
- Raked header with a translucent fiberglass top
- Face curtains have fiberglass stays for added rigidity
- Aluminum angle face edging on the head frame
- Detachable side curtains and draft pads have Velcro® for easy removal
- Heavy-duty galvanized mounting hardware
- Wind straps on the head curtain keep it from being blown out of position
- All sew lines are lock-stitched and reinforced with UV-resistant thread
- 15-inch yellow guide stripe

OPTIONS:

- Full-height yellow guide stripes
- Customizable height, projection and head curtain
- 2-inch foam-filled front head curtain
- Pull rope for head curtain
- Hook-and-loop splits on head curtain
- Frame cut-outs for obstructions
- Common member units
- Ground-level units
- Chain-weighted head curtain
- Spring steel stays

NOVA SOFT SIDED (SS) DOCK SHELTER

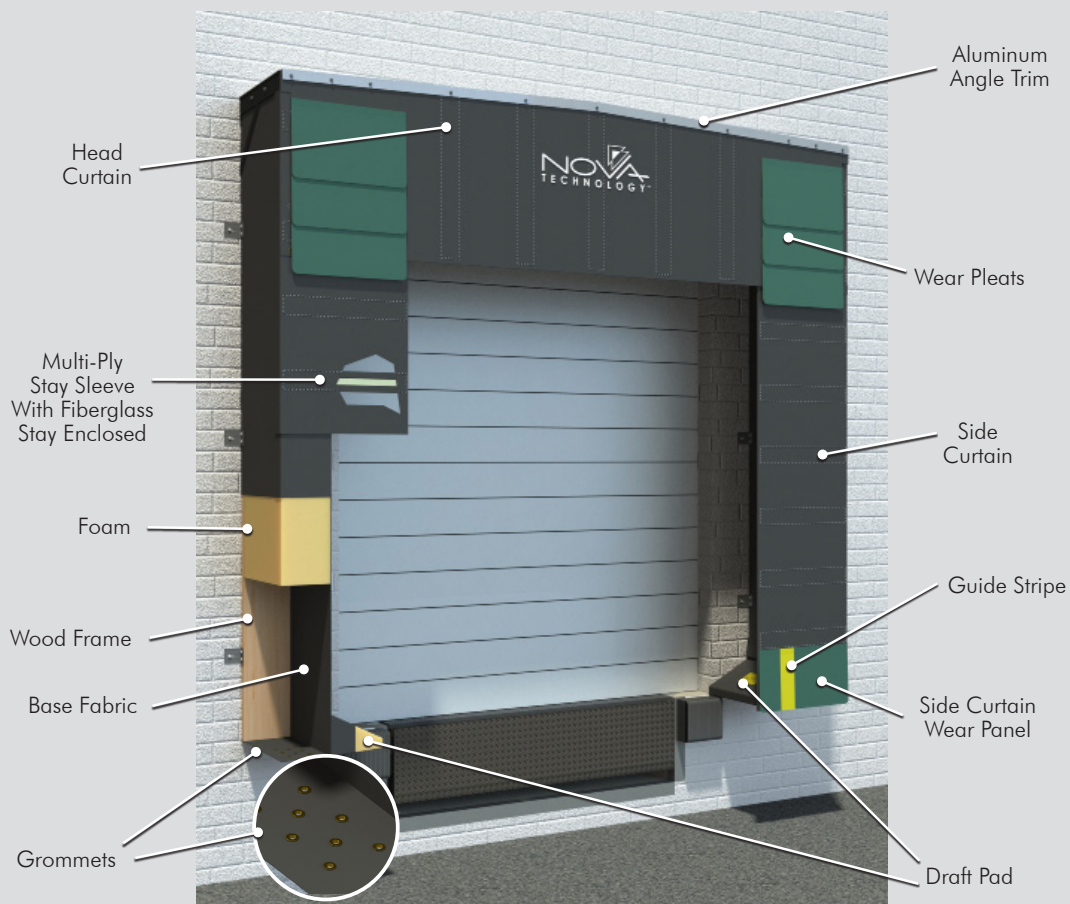

DESIGNED FOR DOOR OPENINGS UP TO 12-FEET WIDE X 12-FEET HIGH

SS Series Soft Sided Dock Shelter—provides maximum dock protection and full access to trailers while minimizing pressure on the building wall. The SS Dock Shelter has soft foam sides for added flexibility and is able to compress and bend out of the way of a truck that approaches the doorway off-center or misaligns with the dock. It is designed to be pliable to prevent damage, downtime and costly repairs.

- Flexible side pad structure protects the unit against damage from off-center trailers
- High-density polyurethane foam for added resiliency
- Frame is made from pressure-treated, kiln-dried wood
- Foam is bonded to the frame with high-strength adhesive
- Available in several top-grade fabric types, weights and colors
- Raked header with a translucent fiberglass top
- Face curtains have fiberglass stays for added rigidity
- Aluminum angle face edging on the head frame
- Detachable side curtains and draft pads have Velcro® for easy removal
- Heavy-duty galvanized mounting hardware
- Wind straps on the head curtain keep it from being blown out of position
- All sew lines are lock-stitched and reinforced with UV-resistant thread
- 15-inch yellow guide stripe

OPTIONS:

- Full-height yellow guide stripes
- Customizable height, projection and head frame
- 2-inch foam-filled front head curtain
- Pull rope for head curtain
- Hook and loop splits on head curtain
- Frame cut-outs for obstructions
- Common member units
- Ground-level units
- Chain-weighted head curtain
- Spring steel stays

NOVA RAIN DEFLECTOR XTREME (RD) DOCK SHELTER

RD XTREME SERIES DOCK SHELTER—provides an excellent barrier to water runoff from the tops of trailers entering the building, especially at declined docks. The RD Xtreme is designed for docks that service a wide range of vehicles and can seal most trailer sizes. Designed for versatility, it is compatible with all dock seals and most dock shelters.

- Multi-layer water defense system
- Mounts over existing seals and shelters or can be combined with a new installation for a seamless product
- Covers truck heights ranging from 12'6 to 13'6-inches
- 20-inch projection beyond the seal/shelter for greater coverage
- 5-inch foam-filled pad deters water runoff from trailer tops
- High-density polyurethane foam for added resiliency
- Frame is made from pressure-treated, kiln-dried wood
- Side flaps with stay pockets for draft protection
- Heavy-duty steel brackets provide reinforced snow load support
- Raked header for enhanced water drainage
- Header has a translucent fiberglass top
- Face is removable for quick replacements when necessary
- All sew lines are lock-stitched and reinforced with UV-resistant thread

OPTIONS:

- Custom projection up to 48-inches total from wall
- Traditional head curtain
- Pad drop over 44-inches
- Frame cut-outs for obstructions
- Galvanized steel head frame
- Spring steel stays
- Overhead cable supports*

* Cables required for certain applications



NOVA

OPTIONS AND ACCESSORIES

DOCK SEAL RECOVERS

- NOVA manufactures dock seal covers made to your specification

FIELD INSTALLED DROP CURTAIN—designed to seal any gap between the trailer and head pad. The drop curtain wraps around the entire head pad, starting at the wood frame at the top, wrapping around the face and then secured to the wood backer. The drop curtain is pre-sewn onto the base and hangs independently. Drop curtains install below the head pad to create a better seal and cover lower trucks.

- Available in several top-grade fabric types, weights and colors
- Compatible with Nova FP and FPU models, and can be retrofitted onto other existing units
- Features 12, 18, or 24-inch drop curtain from the bottom of the head pad
- All sew lines are lock-stitched and reinforced with UV-resistant thread

OPTIONS:

- 2-inch foam-filled drop curtains
- Chain-weighted drop curtain
- Custom sizes and retrofits available
- Drop curtains, available with or without a pull rope and Velcro® attachments

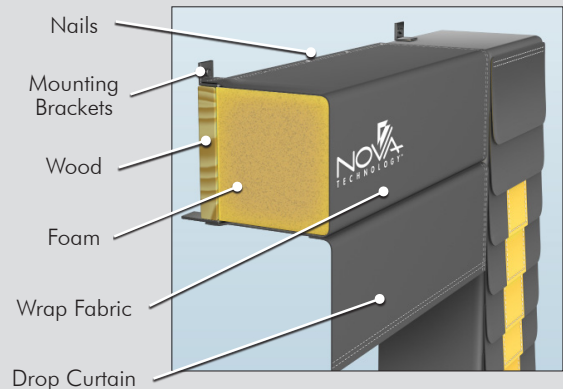
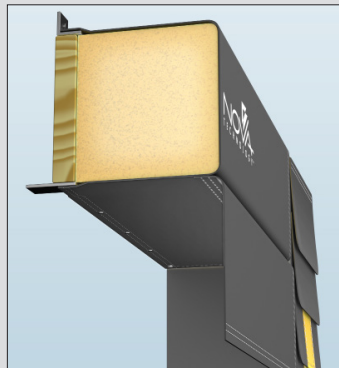

METAL HOOD CANOPIES—designed to protect loading docks and man doors from snow, ice and rain. Metal Hood Canopies redirect precipitation to keep entryways dry and safe for vehicles and pedestrians.

- 4 to 6-feet widths for man doors
- 10 to 12-feet widths for loading docks
- Made of galvanized steel
- Three support gussets
- Full-width 2 x 2-inch rain gutter
- Features 12, 18, 24, and 30-inch standard projections
- Pre-drilled hole alignment for easy installation
- High load capacity

OPTIONS:

- Custom lengths and sizes available
- Installation of a metal hood over 30-inch projection requires using cable stringers to attach to the wall for added support (not included)
- Powder-coated finish with choice of color

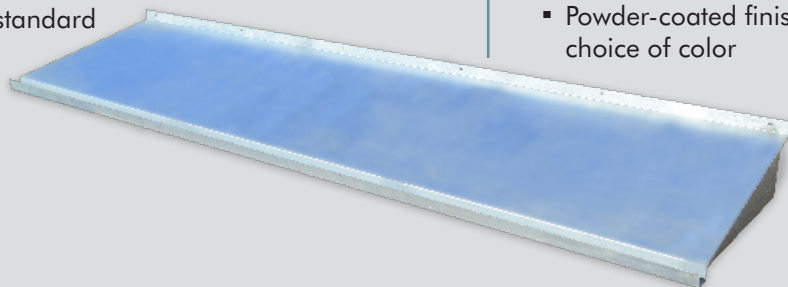

NOVA

OPTIONS AND ACCESSORIES

VERTICAL LEVELER BOTTOM PAD—

designed to maximize environmental and temperature control while vertical-storing levelers are in use. The bottom pad attaches to the underside of the leveler utilizing compression foam to seal gaps between the bumper mounting brackets, bumpers and pit floor and to eliminate air infiltration from underneath the leveler while preventing bugs, pests, dirt and debris from entering the loading area.



- Compatible with any brand, style or size vertical leveler
- Custom made and sized to fit any pit depth requirements
- Quick and easy to mount
- Made from high-performance materials and fabrics
- Open-cell polyurethane compression foam side pads
- Horizontal middle sections feature 1-5-inch foam
- Chain-weighted bottom
- Velcro® attachments for easy pad repositioning and removal
- Fabric wiper on both ends seal the sides of the pit
- Notched, reinforced hem for a universal fit and extra mounting durability
- All seams are lock-stitched



WEAR PLEAT

Multi-layer, reinforced Wear Pleats on the full height of side pads and corners of head pad provide maximum protection to extend life of the seal. Available with 4, 8 or 16-inch exposures.

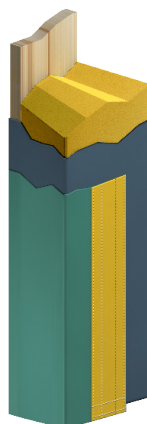

SCUFF GUARD

Scuff Guards protect the inside of side pads from freight and can be full height or 48-inches high.

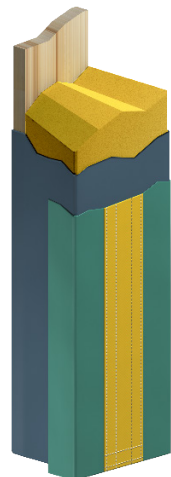

WEAR FACE

The Wear Face reinforces the entire contact surface of the side pad or head pad for greater durability.

NOVA OPTIONS AND ACCESSORIES

Available Fabrics

NOVA MAX-1000™

Heavy-duty polyester-based fabric with a polymer blend coating for maximum durability for high-traffic docks, resulting in the highest puncture, tear and abrasion resistance of any fabric in the industry.

NOVA MAX-60™

Heavy-duty polyester-based fabric with a polymer blend coating on both

sides, with 60% of the coating on the outside surface for greater wear resistance.

40 Oz. NOVALON™*

Nylon woven base with a synthetic elastomer coating on both sides.

40 Oz. Vinyl

Woven polyester base fabric with a vinyl coating on both sides.

22 Oz. Vinyl

Woven polyester-based fabric with a vinyl coating on both sides.

16 Oz. NOVALON™*

Nylon woven base with a synthetic elastomer coating on both sides.

*NOVALON™ is the equivalent replacement for Hypalon®. Hypalon® is a trade name used by DuPont and is no longer available.

FABRIC PROPERTIES & COLORS							
Fabric	Abrasion Resistance (cycles) Fed Std 5306 ASTM D3884	Tensile Strength (lbs./in.) Fed Std 5100 ASTM D751	Tear Strength (lbs., WxL) Fed Std 5134 ASTM D2261	Cold Resistance (at -40°F) Fed Std 5874 ASTM D2136	Colors		
NOVA MAX-1000™	65000	1000 x 1000	200 x 200	Pass	Black	White	White
NOVA MAX-60™	3000	950 x 850	160 x 130	Pass	Black	White	White
40 oz. NOVALON™	1500	400 x 350	50 x 50	Pass	Black	White	White
16 oz. NOVALON™	100	400 x 350	50 x 40	Pass	Black	White	White
40 oz. Vinyl	3000	950 x 850	160 x 130	Pass	Black	Blue	Green
22 oz. Vinyl	1850	695 x 650	120 x 100	Pass	Black	Blue	Green

FLAME-RETARDANT FABRIC

Many of our fabrics offer optional flame-retardant designs. These fabrics are engineered or tested to the strict standards of the California State Title 19 and NFPA-701.

These flame-retardant fabrics are designed to self-extinguish a flame in two seconds or less once the source is removed.

NOVA

ENERGY SAVING PRODUCTS

BOTTOM SEALS—provides environmental and pest control by filling the gaps between the overhead dock door and the dock leveler/floor. They keep rain, snow, dust and rodents out while protecting against drafts and saving energy on heating/cooling costs.

- Made of 2 x 2-inch high-density foam
- Covered with 22-ounce Vinyl or 16-ounce NOVALON™
- Length is custom fit to each order
- Double flap attachment for overhead dock doors
- Single flap construction for freezer doors
- Folded ends, without stitched seams, keep moisture out when compressed
- 3 x 3-inch available for rail car doors
- Heavier fabrics are available upon request

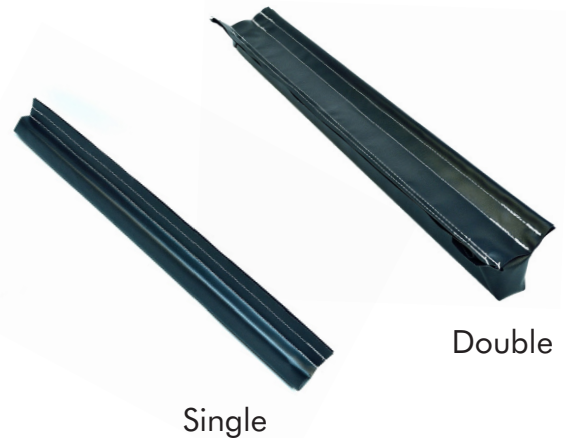

BUMPER COVER PADS—fills the gap under the side pad and between leveler and dock bumper.

- Foam pad
- Cover with no step flap
- Mounting hardware
- Custom sizes available



DOOR FANGS—fills the gap between the dock leveler deck and the curb angles. Door fangs attach to the overhead door, and when the door is closed, they wedge into the gaps to save on heating and cooling costs.

- Wedge measures 2-inches wide x 2-inches high x 1 1/2-inch deep
- Includes a 9 1/2-inch strap for attachment to a 2-inch thick overhead door
- Strap is made of NOVA MAX-60™ Vinyl
- Wedge is covered with ripstop nylon and is filled with high-density foam
- Installation is quick and simple
- Custom sizes available



NOVA

ENERGY SAVINGS PRODUCTS

DOCK LEVELER CURTAINS

CUSTOM DOCK LEVELER

CURTAIN—The Nova Dock Leveler Curtain (DLC) seals the pit while the leveler is in use to help prevent loss of heating and cooling energy from the building. It also helps prevent dust, debris and pests from entering the building. Velcro® attachments across the top of the leveler header allow easy entry for performing leveler maintenance. The DLC is custom fit to any brand of dock leveler.

- Top-grade fabrics provide superior performance and maximum durability
- Made from 22 Oz. Vinyl
- Durable, high chemical resistance
- Combination of retractor straps and fiberglass stays enable curtain to retract and neatly store beneath leveler
- Easy installation—requires no maintenance
- Customized to fit your dock leveler (custom drawing is required for any “cut-out” needed)

STOCK DOCK LEVELER CURTAIN—The Nova Stock Dock Leveler Curtain (DLC) has all the benefits of the custom version, with the convenience of easy field installation. Instead of taking measurements for a custom fit, our Stock DLC can be cut to size by technicians at the moment of installation. The seams are lock-stitched to prevent seams from coming undone after being cut.

- No measuring required
- Simply cut to size while installing
- All sew lines are lock-stitched and reinforced with UV-resistant thread

DOCK STUFFERS—block the gap between the bumper and dock seal. An economical way to eliminate the gap created during the loading and unloading process. The dock stuffer is simply placed over the gap.

- Top carrying handle for easy placement and removal
- Weighted base provides sealing action
- Filled with high-density polyurethane foam
- Does not interfere with loading or unloading
- Constructed from heavy-duty vinyl fabric
- Yellow vinyl offers high visibility
- Caution “NO STEP” safety labels provide clear warning to dock workers
- Reduces rodent and air infiltration
- Includes 36-inch Neoline rope retention system mounted to inside of building
- 15 x 15 x 15-inch triangular-shaped wedge
- Available in 12, 18, 24, and 30-inch lengths

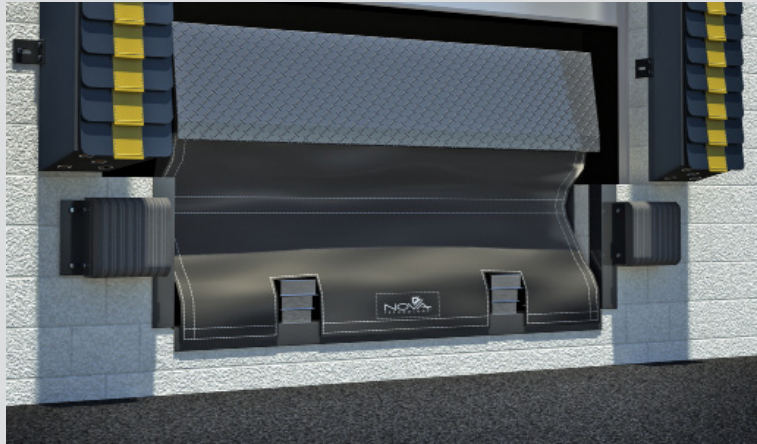

OPTIONS:

- Wide selection of fabric types, weights and colors



OPTIONS:

- Custom lengths available

LOADING DOCK EQUIPMENT PRODUCTS BUILT FOR SAFETY, RELIABILITY AND STRENGTH



VEHICLE RESTRAINTS

The most effective way to prevent accidents caused by trucks and trailers from prematurely pulling away from docks during loading and unloading.



DOCK LEVELERS

Allow forklifts to make a smooth, safe transition between loading dock and trailer, reducing the effects of dock shock and the jarring that occurs when a lift truck crosses between the warehouse floor and trailer bed.



SEALS AND SHELTERS

A wide variety of designs to fit your facility's needs for vehicle type, door size, dock height, driveway grade, dock traffic and weather conditions.



SAFETY BARRIER PRODUCTS

Reduce your risk of injury as well as damage to your building, equipment and products.



LOADING DOCK ACCESSORIES

Comprehensive line of loading dock accessories and loading dock aftermarket products to improve safety, productivity, security and environmental control.

Since 1986, NOVA has been providing innovation and reliability to the loading dock industry. We manufacture and distribute a comprehensive line of vehicle restraints, mechanical, air-powered and hydraulic dock levelers, edge-of-dock levelers, dock seals and shelters, safety barrier products, and other loading dock accessories to improve safety, productivity, security and environmental control.

For a dealer in your area or for additional information on routine service, preventative maintenance, product questions, or to request a quote, contact NOVA Technology.



1-800-236-7325
www.novalocks.com